

Application Example

Normally Unlocked Locking Solenoid Switch to Safety Relay with Dual Safety Circuit

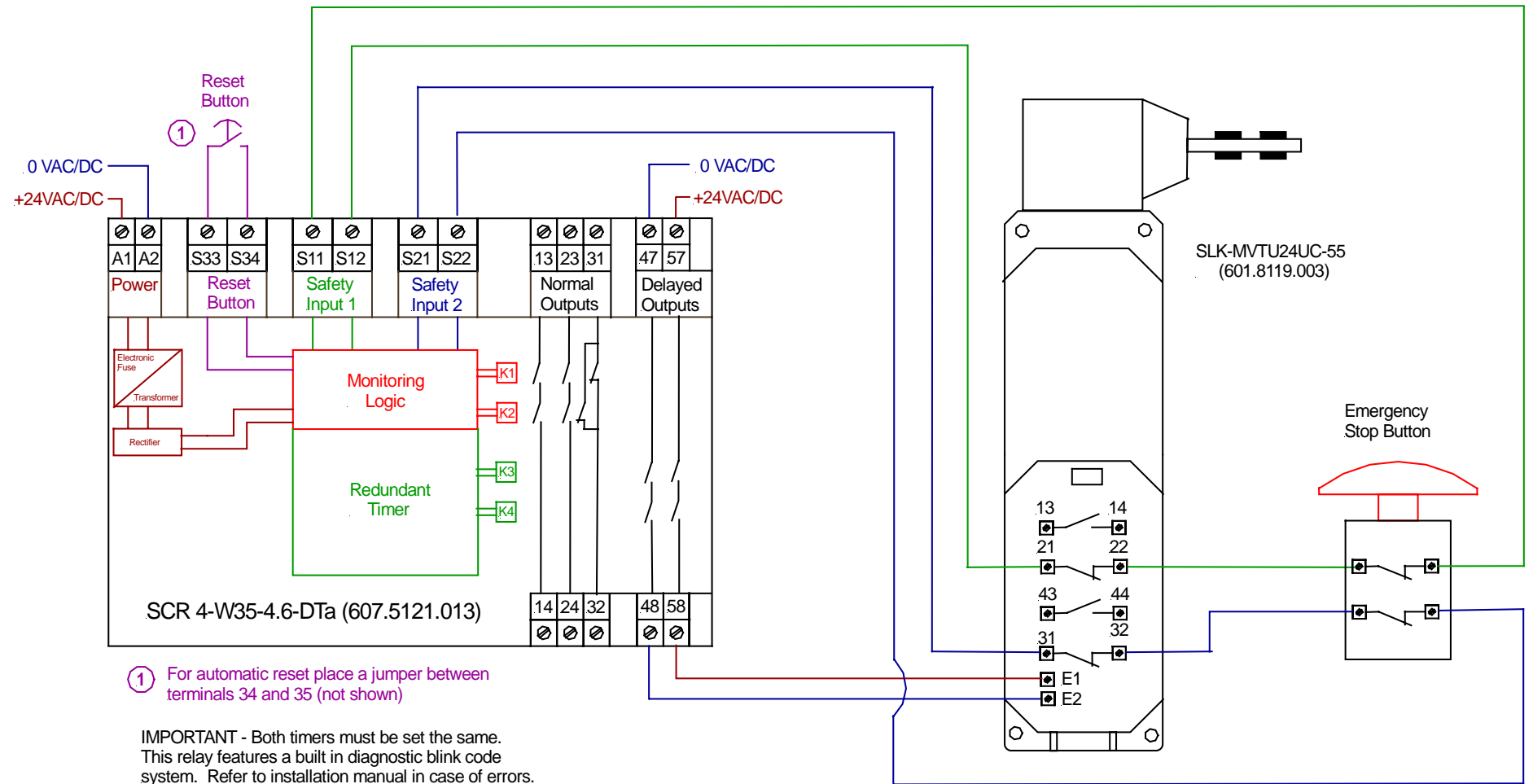

This drawing is provided as a typical application example, for review purposes only. Additional changes may be needed in order to meet the conditions of the safety levels required for your application and to properly interface with your control system. A risk assessment should be performed by the user to determine the actual safety level required. Machine Safety Direct does not assume any responsibility for personnel safety or injuries and disclaims any liability for the failure of the safety system installation to meet the requirements of the actual level of safety needed by the user. It is the responsibility of the user to ensure that all control devices are correctly installed, cared for and operated to meet all applicable codes, standards and regulations.

Drawing Name	Unlocked Safety Solenoid Switch	
Revision #	001	
Date Created	04/16/08	
By	ME	Verified by